

- NOTES:
- 1) APPROXIMATE DRY WEIGHT WITH QUAD YAMAHA 425HP ENGINES IS 28,000 POUNDS
  - 2) APPROXIMATE WEIGHT WITH FULL FLUIDS AND 2ND STATION IS 33,500 POUNDS
  - 3) APPROXIMATE LOCATION OF THE CENTER OF GRAVITY WITH FULL FLUIDS IS SHOWN
  - 4) DRAFT SHOWN AT HALF FLUIDS WITH OPTIONS

REV	DESCRIPTION	HULL DATE	CLW DATE
B	ADDED DETAIL FOR KVH WITHOUT THE 2ND STATION	16	3-24-23

**EVERGLADES**  
 R.J. Dougherty Associates  
 544 S Airpark rd.  
 Edgewater, FL 32132-3043  
 386-4092202

Title:	GRAVING PLAN	Dwg No:	455-611-01	Scale:	1:48	Drawn by:	CLW
Model:	455CC	Sheet:	1 OF 4	Date:	3/14/2023	Appr by:	
		Chkd by:					

1

2

3

4

5

6

A

B

C

D

SECTION A-A

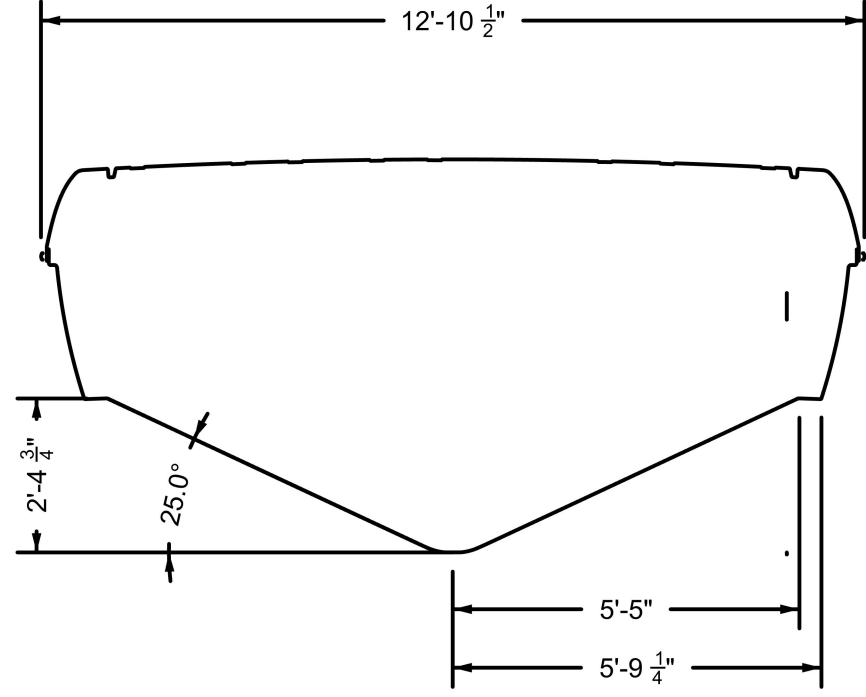

SECTION B-B

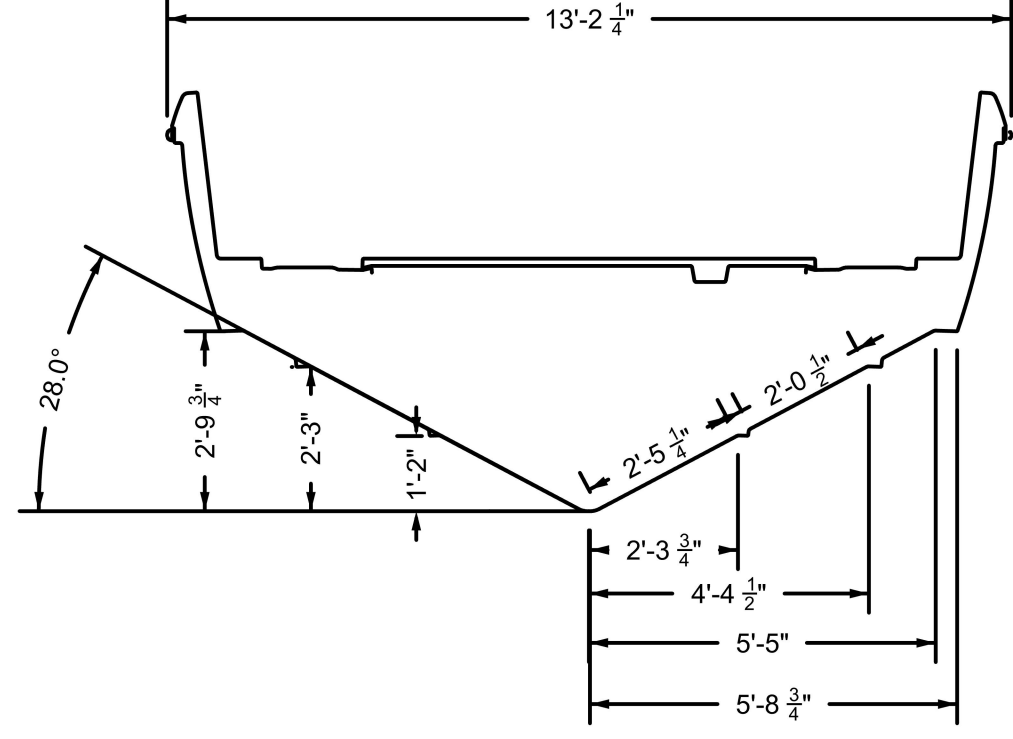

SECTION C-C

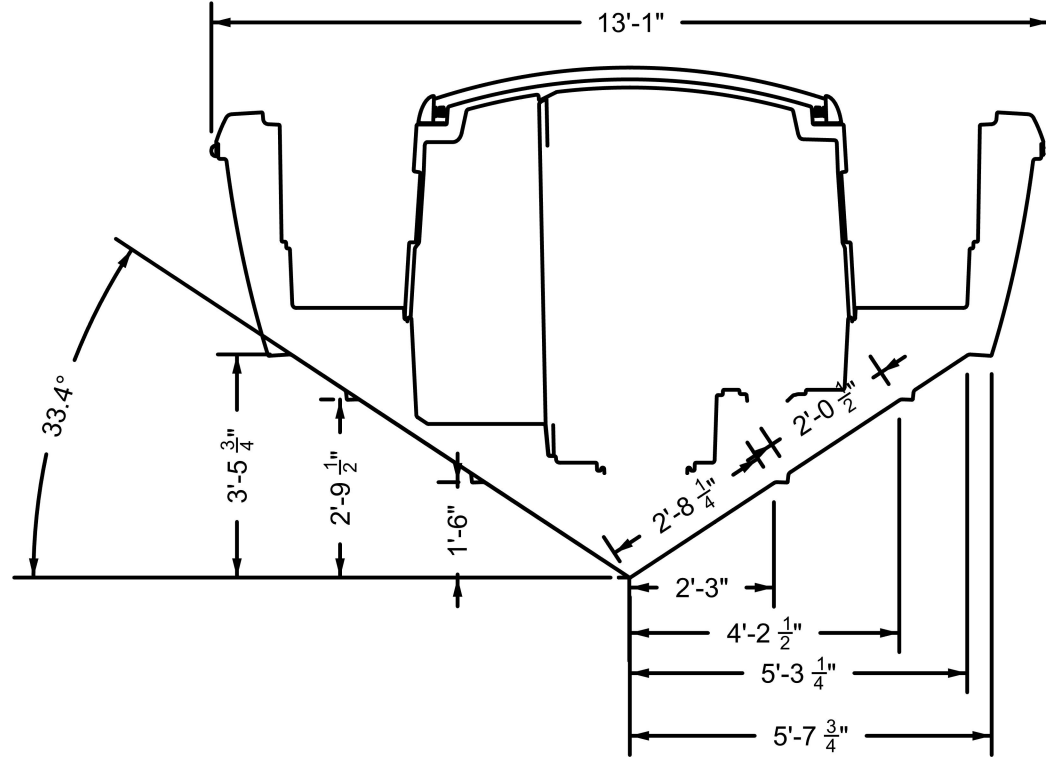

B	ADDED DETAIL FOR KVH WITHOUT THE 2ND STATION	16	3-24-23	CLW
A	ADDED SHEET 3 SHOWING FOLDED SECOND STATION HEIGHT AND DRAFT. ADJUSTED CENTER OF GRAVITY	1	5-5-21	JSE
REV	DESCRIPTION	HULL	DATE	APPR BY

**EVERGIADAS**  
 RJ Dougherty Associates  
 544 S Airpark rd.  
 Edgewater, FL 32132-3043  
 386-4092202

Title:	GRAVING PLAN	Dwg No:	455-611-01	Scale:	1:48	Drawn by:	CLW
Model:	455CC	Sheet:	2 OF 4	Date:	3/14/2023	Appr by:	Chkd by:

1

2

3

4

5

6

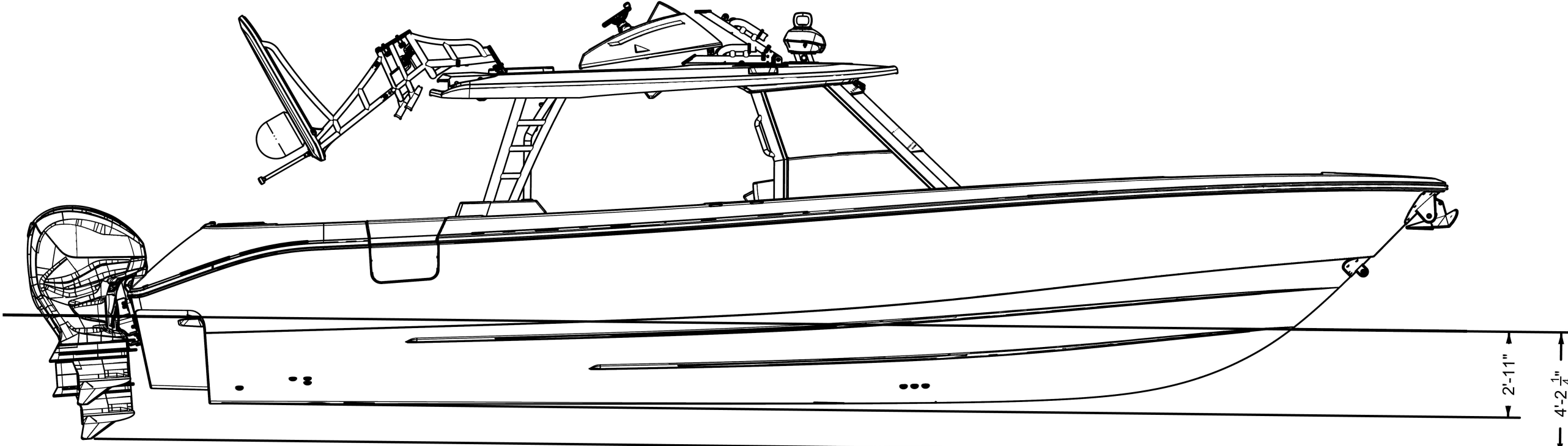
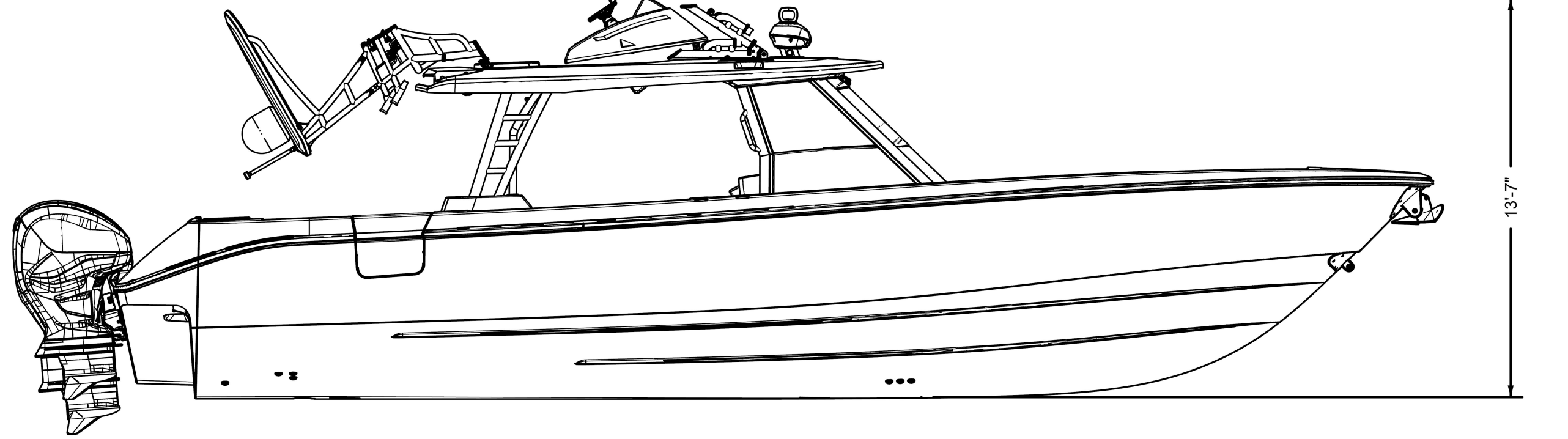

B	ADDED DETAIL FOR KVH WITHOUT THE 2ND STATION	16	3-24-23	CLW
A	ADDED SHEET 3 SHOWING FOLDED SECOND STATION HEIGHT AND DRAFT. ADJUSTED CENTER OF GRAVITY	1	5-5-21	JSE
REV	DESCRIPTION	HULL	DATE	APPR BY

**EVERGIADAS**  
**RJ Dougherty Associates**  
**544 S Airpark rd.**  
**Edgewater, FL 32132-3043**  
**386-4092202**

Title: GRAVING PLAN		Scale: 1:48	Dwg No: 455-611-01	Drawn by: CLW
Model: 455CC	Part No.	Date: 3/14/2023	Sheet: 3 OF 4	Appr by: Chkd by:

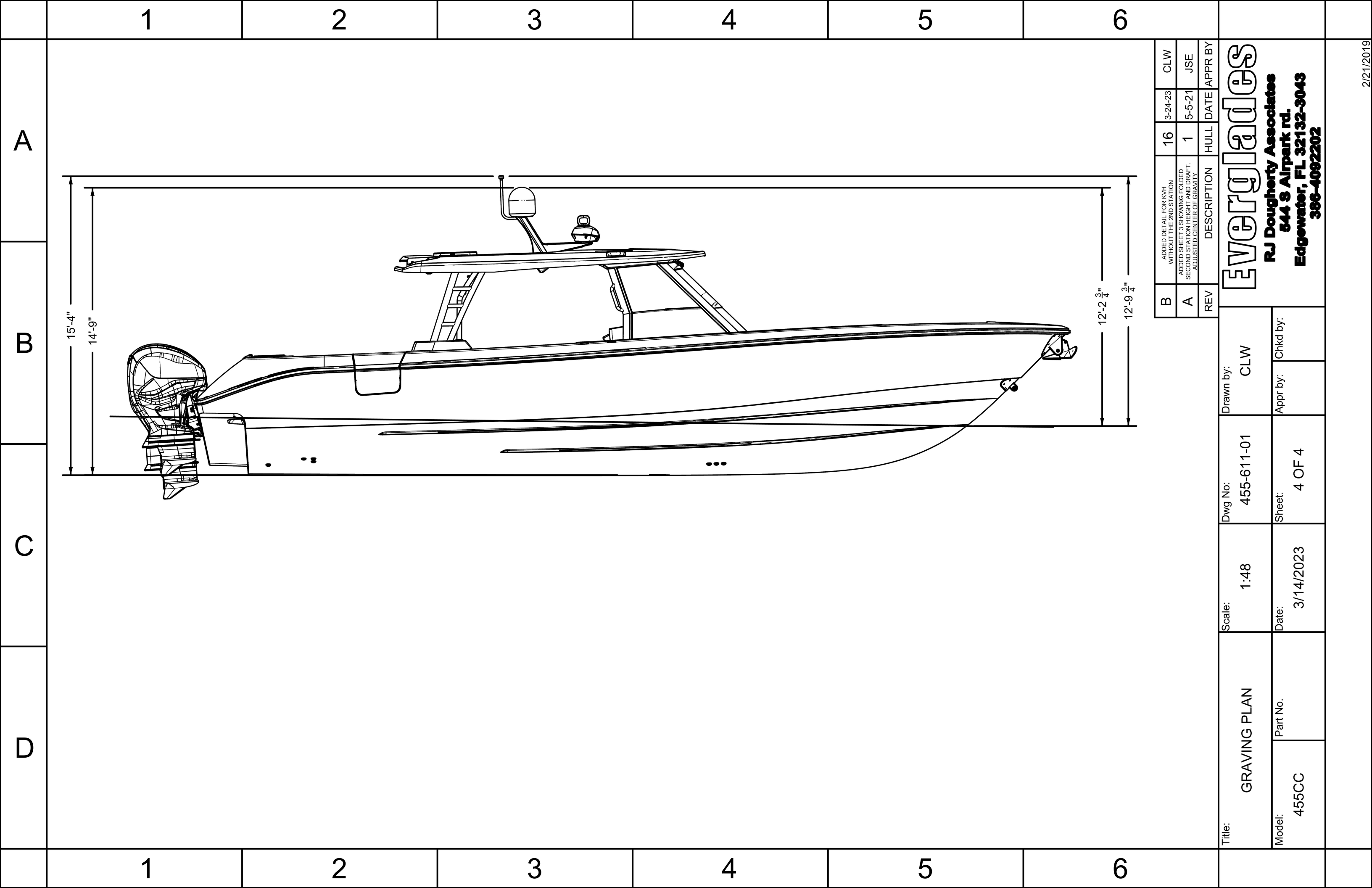

B	ADDED DETAIL FOR KVH WITHOUT THE 2ND STATION	16	3-24-23	CLW
A	ADDED SHEET 3 SHOWING FOLDED SECOND STATION HEIGHT AND DRAFT. ADJUSTED CENTER OF GRAVITY	1	5-5-21	JSE
REV	DESCRIPTION	HULL	DATE	APPR BY

**EVERGIADAS**  
**RJ Dougherty Associates**  
**544 S Airpark rd.**  
**Edgewater, FL 32132-3043**  
**386-4092202**

Title: GRAVING PLAN		Scale: 1:48	Dwg No: 455-611-01	Drawn by: CLW
Model: 455CC	Part No.	Date: 3/14/2023	Sheet: 4 OF 4	Appr by: Chkd by: