

350cc EVERGLADES
355cc

BOAT SPEC SHEET

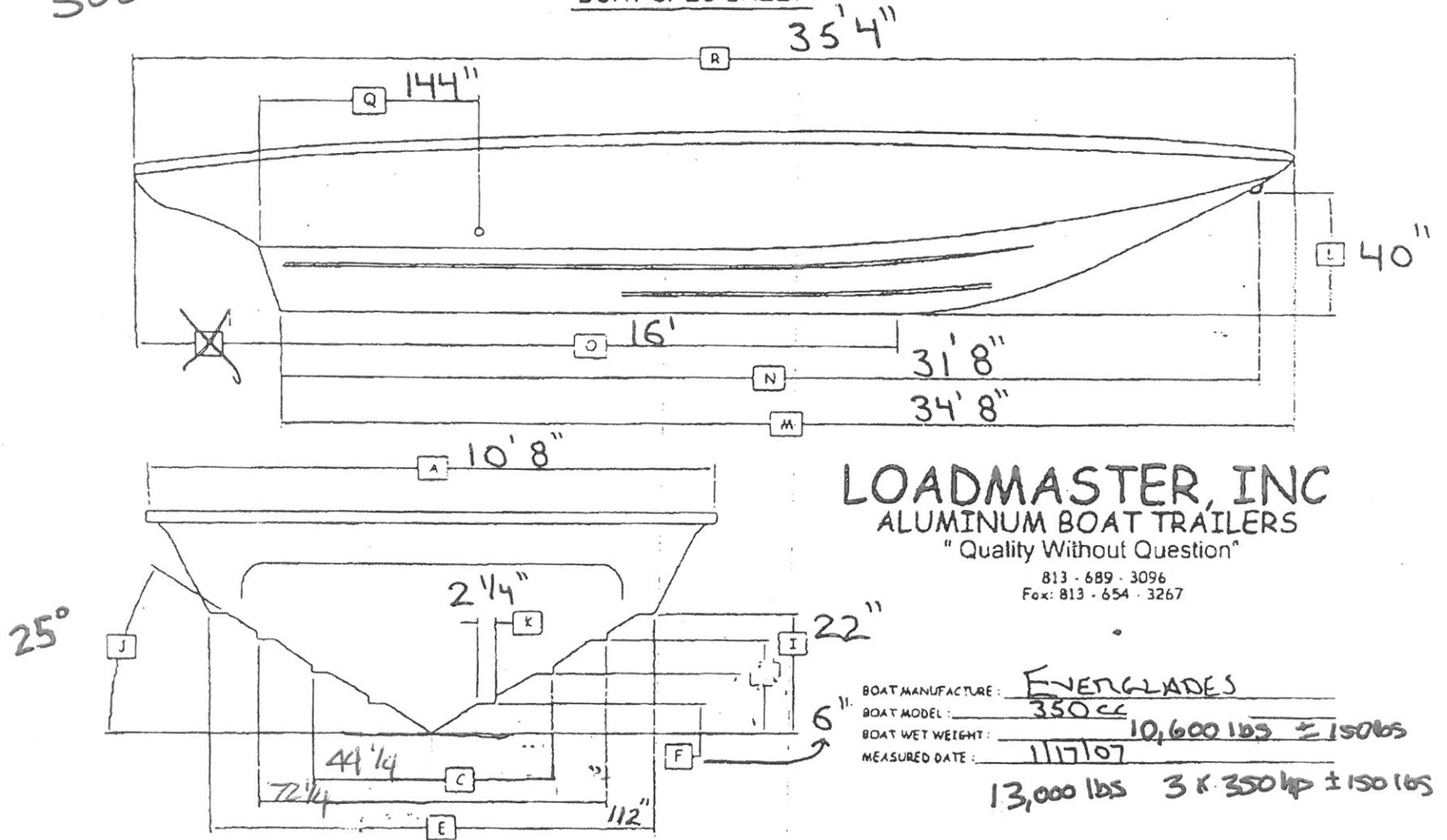

LOADMASTER, INC
ALUMINUM BOAT TRAILERS
"Quality Without Question"

813 - 689 - 3096
Fax: 813 - 654 - 3267

BOAT MANUFACTURE: EVERGLADES
BOAT MODEL: 350cc
BOAT WET WEIGHT: 10,600 lbs ± 150lbs
MEASURED DATE: 11/7/07
13,000 lbs 3K 350hp ± 150 lbs

- A.) MAXIMUM BEAM: _____
- B.) 1st STRAKE: _____
- C.) 2nd STRAKE: _____
- D.) 3rd STRAKE: _____
- E.) MAXIMUM CHINE BEAM: _____
- F.) 1st VERTICAL DROP TO KEEL: _____
- G.) 2nd VERTICAL DROP TO KEEL: _____
- H.) 3rd VERTICAL DROP TO KEEL: _____
- I.) 4th VERTICAL DROP TO KEEL: _____

- J.) DEADRISE AT TRANSOM: _____
- K.) STRAKE WIDTH: _____
- L.) VERTICAL DROP: _____
- M.) BOW TO TRANSOM / KEEL INTERSECTION: _____
- N.) BOW EYE TO TRANSOM / KEEL INTERSECTION: _____
- O.) RUNNING SURFACE AT KEEL: _____
- P.) SWIM PLATFORM: _____
- Q.) CENTER OF GRAVITY: _____
- R.) LENGTH OVERALL: _____